



SPECIAL FEATURES

- CE & ATEX APPROVED ELECTRICAL CONTACTS
- STAINLESS STEEL CASE & MEASURING SYSTEM
- SELECTABLE RANGES FROM
 - 6000 to 0 & 0 to 6000 mmWC, -1 to 0 & 0 to 25 kg/cm²
- FLANGED OR SCREWED CONNECTION
- STANDARD FOLLOWED IN GENERAL EN 837 - 3

APPLICATIONS

SUITABLE FOR CLEAN AIR, CORROSIVE ENVIRONMENTS & GASEOUS OR NON CRYSTALLIZED LIQUID MEDIA THAT WILL NOT OBSTRUCT THE PRESSURE SYSTEM.



SPECIFICATIONS

STANDARD VERSION : 100 mm & 150 mm

Diaphragm Type	: HP : -1 to 0 kg/cm ² & 0 to 25 kg/cm ² LP : -6000 mmWC to 0 & 0 to 6000 mmWC
Accuracy	: ±1.6% of F. S.
Ambient temperature	: - 25°C to + 65°C
Process temperature	: Max 100°C
Operating pressure range	: 75 % of Scale Value
Over pressure limit	: 125 % of Scale Value
Case & Bezel	: AISI 304 SS (Bayonet Type)
Top Chamber	: AISI 304 SS
Bottom Chamber	: AISI 316 SS
Movement	: AISI 304 SS
Diaphragm	: AISI 316L SS
Gauge Connection	: ½" BSP (M)
Protection	: IP 65
Dial	: Aluminum, black graduation on white background
Pointer	: Aluminum, black coloured, micrometer zero adjustable
Window	: Sheet Glass
Blow off Disc	: Neoprene
Gasket	: Neoprene

GLYCERINE FILLED VERSION (OPTION PY)*

Accuracy	: ±2.5 % of F. S.
Ambient Temperature	: Maximum 65°C
Process Temperature	: Maximum 65°C
Window	: Plexi Glass
Dampening Liquids	: Glycerine 99.7% (others available as option)
Other Features	: Refer Specification of Standard Version

* Consult factory for ranges.

ELECTRICAL CONTACT - DRY VERSION

Accuracy	: ±2.5% of F. S.
Ambient Temperature	: Maximum 65°C
Process Temperature	: Maximum 65°C
Window	: Polycarbonate Dome
Dampening Liquid	: Dielectric Oil (Optional)
Electrical Contacts*	: Refer How to Order
Other Features	: Refer Specification of Standard Version

* Please specify contact set points while ordering.

Temperature effect:

The variation of indication caused by effects of temperature is to be calculated by below formula; which is to be added in the specified accuracy while measurement :- Formula : $\pm 0.08 \times (t_2 - t_1) \% \text{ of F. S.}$
where t1 = reference temperature (+20°C) and t2 = ambient temperature in °C.

Note : The addition of mechanical electric contacts affects the accuracy of instruments such that 1% becomes 1.5%, 1.6% becomes 2.4% etc. (Add the 50% of accuracy; If the contact is of the magnetically assisted type, this value can't be added within the ±5% of setting point.)

DIMENSIONS - STANDARD VERSION

TYPE : 2

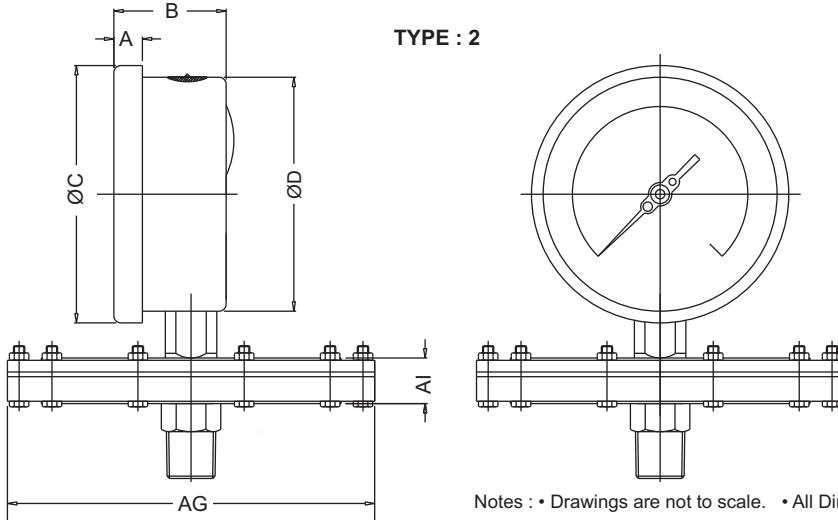

NS	A	B	ØC	ØD	AG*	AI	Weight in gram (With Box)	Type
100	12.5	47	111	100	158	17.5	2600	LP
150	15	49	161	149	158	17.5	3080	LP
100	12.5	47	111	100	98	19	1560	HP
150	16	49	161	149	98	19	2020	HP

LP Type = -6000 mmWC to 0 & 0 to 6000 mmWC
 HP Type = -1 kg/cm² to 0 & 0 to 25 kg/cm²

Notes : • Drawings are not to scale. • All Dimensions are in mm. • NS = Nominal Size.

RANGE TABLE

Note : Waaree offers National / International Scales like kPa, MPa, bar, psi, kg/cm² & Dual Scale like kPa with psi, kPa with bar, bar with psi or Equivalent scales as per the requirement can be provided on request. Following are the example tables for kg/cm² & psi scales

PRESSURE, VACUUM & COMPOUND RANGES (HP)

PRESSURE RANGE

SINGLE SCALE - kg/cm ²					
0/0.6	0/1.6	0/4	0/10	0/21	
0/1	0/2.5	0/6	0/16		

DUAL SCALE - kg/cm ² with psi					
psi	kg/cm ²	psi	kg/cm ²	psi	kg/cm ²
0/15	0/1	0/100	0/7	0/300	0/21
0/30	0/2	0/150	0/10		
0/60	0/4	0/220	0/16		

VACUUM & COMPOUND RANGE

SINGLE SCALE - kg/cm ²					
-1/0.6	-1/3	-1/9	-1/20		
-1/1.5	-1/5	-1/15			

DUAL SCALE - kg/cm ² with psi					
inHg with psi	mmHg with kg/cm ²	inHg with psi	mmHg with kg/cm ²	inHg with psi	mmHg with kg/cm ²
-30/0	-760/0	-30/60	-760/4	-30/200	-760/14
-30/15	-760/1	-30/100	-760/7	-30/300	-760/20
-30/30	-760/2	-30/150	-760/10		

PRESSURE, VACUUM & COMPOUND RANGES (LP)

PRESSURE RANGE

SINGLE SCALE - mmWC (LP)		
0/250	0/1000	0/2500
0/400	0/1600	0/4000
0/600	0/2000	0/6000

VACUUM & COMPOUND RANGE

SINGLE SCALE - mmWC (VACUUM)		
- 250/0	- 1000/0	- 2500/0
- 400/0	- 1600/0	- 4000/0
- 600/0	- 2000/0	- 6000/0

SINGLE SCALE - mmWC (COMPOUND)		
- 100/150	- 400/600	- 1000/1500
- 150/250	- 600/1000	- 1500/2500
- 200/400	- 800/1200	- 2000/4000

ACCESSORIES (Refer Datasheet for complete specifications)

EC	GAUGE COCK	EG	SNUBBER	EB	COOLING TOWER
*	NEEDLE VALVE	EH	SIPHON	ED	OVERLOAD PROTECTOR (GAUGE SAVER)**

* Refer catalogue for valves and manifolds

** For Pressure Ranges 2500 mmWC & above

WIRING DIAGRAMS FOR ELECTRIC CONTACTS

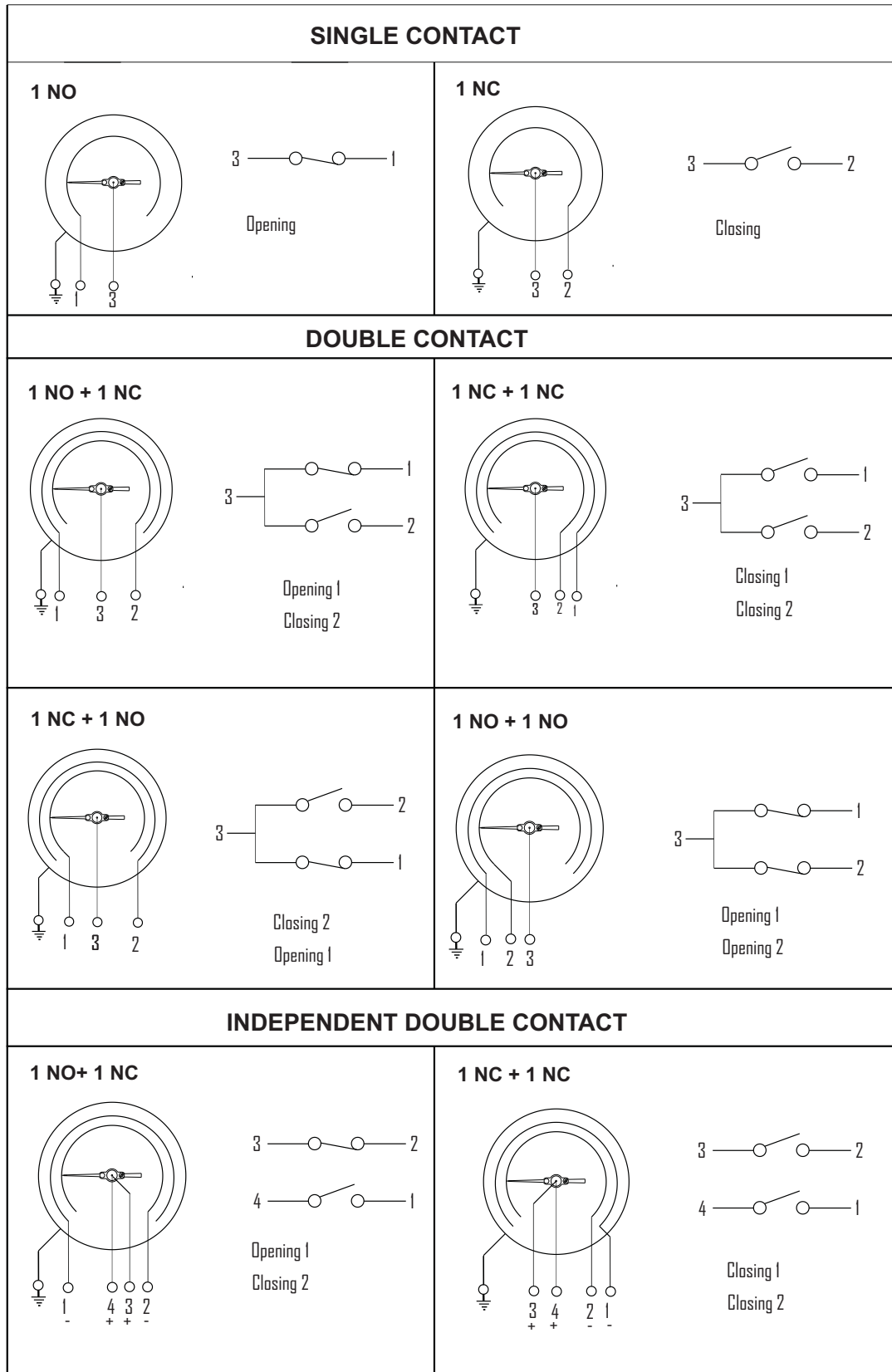

FLANGE TABLE WITH ORDERING CODES

HOW TO SELECT

e.g. FOR FLANGE SIZE OF 1 " AS PER BS-10 TABLE E WITH RAISED FACE : B97 - A2

A2 RAISED FACE

A3 FLAT FACE

AS PER DIN 2527

DN	PN	CODE	
10	6	A01	
	10	A02	
	16	A03	
	25	A04	
	40	A05	
	64	A06	
	100	A07	
	160	A08	
	250	A09	
	400	A10	
15	6	A11	
	10	A12	
	16	A13	
	25	A14	
	40	A15	
	64	A16	
	100	A17	
	160	A18	
	250	A19	
	400	A20	
20	6	A21	
	10	A22	
	16	A23	
	25	A24	
	40	A25	
25	6	A26	
	10	A27	
	16	A28	
	25	A29	
	40	A30	
	64	A31	
	100	A32	
	160	A33	
250	A34		
400	A35		
32	6	A36	
	10	A37	
	16	A38	
	25	A39	
	40	A40	
	40	6	A41
		10	A42
		16	A43
25		A44	
40		A45	
64		A46	
100		A47	
160		A48	
250	A49		
400	A50		
50	6	A51	
	10	A52	
	16	A53	
	25	A54	
	40	A55	
	64	A56	
	100	A57	
	160	A58	
	250	A59	
	400	A60	

DN	PN	CODE
65	6	A61
	10	A62
	16	A63
	25	A64
	40	A65
	64	A66
	100	A67
	160	A68
	250	A69
	400	A70
80	6	A71
	10	A72
	16	A73
	25	A74
	40	A75
	64	A76
	100	A77
	160	A78
	250	A79
	400	A80

AS PER JIS - B 2210

NOMINAL SIZE	RATING /CLASS	CODE
10A	5K	B57
	10K	B58
	40K	B59
15A	5K	B60
	10K	B61
	40K	B62
20A	5K	B63
	10K	B64
	40K	B65

NOMINAL SIZE	RATING /CLASS	CODE
25A	5K	B66
	10K	B67
	40K	B68
32A	5K	B69
	10K	B70
	40K	B71
40A	5K	B72
	10K	B73
	40K	B74

NOMINAL SIZE	RATING /CLASS	CODE
50A	5K	B75
	10K	B76
	40K	B77
65A	5K	B78
	10K	B79
	40K	B80
80A	5K	B81
	10K	B82
	40K	B83

AS PER DIN 2642

DN	PN	CODE
10	10	A90
15		A91
20		A92
25		A93
32		A94
40		A95
50		A96
65		A97
80		A98

AS PER DIN 2633

DN	PN	CODE
10	16	A81
15		A82
20		A83
25		A84
32		A85
40		A86
50		A87
65		A88
80		A89

AS PER DIN 2635

DN	PN	CODE
10	40	A99
15		B01
20		B02
25		B03
32		B04
40		B05
50		B06
65		B07
80		B08

AS PER ANSI B 16.5

NOMINAL SIZE	RATING /CLASS	CODE
½"	150	B09
	300	B10
	600	B11
	900	B12
	1500	B13
	2500	B14
¾"	150	B15
	300	B16
	600	B17
	900	B18
	1500	B19
	2500	B20

NOMINAL SIZE	RATING /CLASS	CODE
1"	150	B21
	300	B22
	600	B23
	900	B24
	1500	B25
	2500	B26
1 1/4"	150	B27
	300	B28
	600	B29
	900	B30
	1500	B31
	2500	B32

NOMINAL SIZE	RATING /CLASS	CODE
1 ½"	150	B33
	300	B34
	600	B35
	900	B36
	1500	B37
	2500	B38
2"	150	B39
	300	B40
	600	B41
	900	B42
	1500	B43
	2500	B44

NOMINAL SIZE	RATING /CLASS	CODE
2 ½"	150	B45
	300	B46
	600	B47
	900	B48
	1500	B49
	2500	B50
3"	150	B51
	300	B52
	600	B53
	900	B54
	1500	B55
	2500	B56

AS PER BS - 10

NOMINAL SIZE	TABLE	CODE
½"	D	B84
	E	B85
	F	B86
	H	B87
	J	B88
¾"	K	B89
	D	B90
	E	B91
	F	B92
	H	B93
J	B94	
K	B95	

NOMINAL SIZE	TABLE	CODE
1"	D	B96
	E	B97
	F	B98
	H	B99
	J	C01
1 1/4"	K	C02
	D	C03
	E	C04
	F	C05
	H	C06
J	C07	
K	C08	

NOMINAL SIZE	TABLE	CODE
1 ½"	D	C09
	E	C10
	F	C11
	H	C12
	J	C13
2"	K	C14
	D	C15
	E	C16
	F	C17
	H	C18
J	C19	
K	C20	

NOMINAL SIZE	TABLE	CODE
2 ½"	D	C21
	E	C22
	F	C23
	H	C24
	J	C25
3"	K	C26
	D	C27
	E	C28
	F	C29
	H	C30
J	C31	
K	C32	

Note : 1 Flanged Connections as per BS / ANSI / DIN etc standards with or without Teflon protection can be provided on request.

2 Flange Finish shall be 125 - 250 AARH as a standard. For other finish, please consult factory.

(If the contract is of the magnetically assisted type, this value can't be added within +/- 5% of setting point)

Example

HOW TO ORDER

BASIC MODEL

CODE

AP

NOMINAL SIZE

F H

X

TYPE OF MOUNTING

100 mm 150 mm

X

2 DIRECT BOTTOM ENTRY 6 2" PIPE / YOKE MOUNTING WITH BOTTOM ENTRY*

* MOC OF BRACKET AND 'U' CLAMP WILL BE STEEL. ASK FACTORY FOR DRAWINGS, IF REQUIRED.

TOP CHAMBER

XW AISI 304 SS (Standard) XY AISI 316 SS

XX

DIAPHRAGM

UL HASTELLOY 'C' UM MONEL UJ AISI 316L SS (Standard)

XX

BOTTOM CHAMBER (* Refer Pressure v/s Temperature table below.)

TK AISI 304 SS TZ PVC*
 TL AISI 316L SS UA PVDF*
 UH TITANIUM TY POLYPROPELENE*
 TT HASTELLOY C
 TX MONEL
 TM AISI 316 SS (Standard)

MOC OF BOTTOM CHAMBER	PRESSURE V/S TEMPERATURE					
	20 °C	40 °C	60 °C	80 °C	100 °C	120 °C
PVDF	10 kg/cm ²	10 kg/cm ²	10 kg/cm ²	7 kg/cm ²	4 kg/cm ²	2 kg/cm ²
PP	10 kg/cm ²	10 kg/cm ²	6 kg/cm ²	4 kg/cm ²	1 kg/cm ²	NA
PVC	10 kg/cm ²	10 kg/cm ²	4 kg/cm ²	1 kg/cm ²	NA	NA

XX

PROCESS CONNECTION

4NM 1/2" NPT (M) (Standard) 4TM 1/2" BSPT (M) 3BM 3/8" BSP (M) (Except Option QS)

XXX

4BM 1/2" BSP (M) (Standard) 4MM M20 x 1.5 (M) Flanged* Refer Flange Table with ordering code on previous page

Note : Connections like Metric/ PT/ PF/ Flaired/ UNF/ G/ R etc. can be provided on request. * ASK FACTORY FOR DRAWINGS, IF REQUIRED.

RANGE

REFER RANGE TABLE

OPTIONAL EXTRAS

PW FIVE POINT CALIBRATION CERTIFICATE
 RH CUSTOM DESIGNED DIAL
 RX SHATTERPROOF / SAFETY GLASS
 RZ TOUGHENED GLASS
 SW DIAL TAG MARKING
 SX SS TAG PLATE
 YF TOP CHAMBER IN AISI 316 SS
 SG OXYGEN SERVICE
 JU 2" PIPE/YOKE MOUNTING BRACKET & 'U' CLAMP (AISI 304 SS)
 FN 2" PIPE/YOKE MOUNTING BRACKET & 'U' CLAMP (AISI 316 SS)
 HJ 2.5 TIMES OVER PRESSURE
 QS PTFE LINING ON FLANGE OR SCREWED CONNECTION
 ZT SILVER PROTECTION ON DIAPHRAGM
 QU PTFE PROTECTION ON DIAPHRAGM
 VZ PTFE COATING ON DIAPHRAGM
 VI PTFE GASKET UPTO 200°C
 SD AISI 316 SS MOVEMENT
 PS AISI 316 SS CASE & BEZEL
 PY DAMPENING LIQUID GLYCERINE FILLED
 GH MATERIAL TEST CERTIFICATES#
 ZZ DIELECTRIC OIL FILLED***

0/250
mmWC

XX

* For screwed connection, bore diameter will be minimum 10 mm.

** Suitable for Pressure Ranges only.

*** BOD, Gasket & Filling plug of NBR. Refer Price List for Viton.

MATERIAL TEST CERTIFICATES WILL BE PROVIDED FOR WETTED PARTS ONLY WITH CHEMICAL COMPOSITION TESTING. FOR OTHERS, PLEASE CONSULT FACTORY.

ELECTRIC CONTACTS (Except option RX & RZ)(CE & ATEX APPROVED)

(WITH INGRESS PROTECTION UPTO IP 55 & FOR PRESSURE RANGES FROM 6000 mmWC TO 21 kg/cm²)

INDUCTIVE TYPE (220 V AC, 0.4 Amp.)

YX Double; NORMALLY CLOSED + NORMALLY OPEN (1 NC + 1 NO) YW Single; NORMALLY OPEN (1 NO)
 ZA Double; NORMALLY OPEN + NORMALLY CLOSED (1 NO + 1 NC) YV Single; NORMALLY CLOSED (1 NC)
 YY Double; NORMALLY OPEN (BOTH NO)
 YZ Double; NORMALLY CLOSED (BOTH NC)

XX

Note: THE SCALE AMPLITUDE WILL BE IN BETWEEN 180° TO 270° & WINDOW SHALL BE POLYCARBONATE DOME.

Ordering Example: AP - X - X - XX - XX - XX - XXX - 0/250 mmWC - XX - XX

FOR NON STANDARD PRODUCTS/OPTIONAL ITEMS, PLEASE CONTACT FACTORY FOR DELIVERY AND MINIMUM QUANTITY OF ORDER.

Refer Datasheet EE for selection of Flushing Rings.

Note : Specifications and dimensions given in this product catalogue represents the state of engineering at the time of printing.

Modifications may take place and materials specified may be replaced by others without prior notice.

